



Cambridge International Examinations
Cambridge International General Certificate of Secondary Education

CANDIDATE
NAME

CENTER
NUMBER

--	--	--	--	--

CANDIDATE
NUMBER

--	--	--	--

* 0 7 0 1 9 3 5 0 0 3 *

MATHEMATICS (US)

0444/41

Paper 4 (Extended)

May/June 2014

2 hours 30 minutes

Candidates answer on the Question Paper.

Additional Materials: Geometrical instruments
 Electronic calculator

READ THESE INSTRUCTIONS FIRST

Write your Center number, candidate number and name on all the work you hand in.

Write in dark blue or black pen.

You may use a #2 pencil for any diagrams or graphs.

Do not use staples, paper clips, glue or correction fluid.

DO NOT WRITE IN ANY BARCODES.

Answer **all** questions.

If work is needed for any question it must be shown in the space provided.

Electronic calculators should be used.

If the degree of accuracy is not specified in the question, and if the answer is not exact, give the answer to three significant digits.

Give answers in degrees to one decimal place.

For π , use either your calculator value or 3.142.

The number of points is given in parentheses [] at the end of each question or part question.

The total of the points for this paper is 130.

Write your calculator model in the box below.

This document consists of **20** printed pages.

Formula List

For the equation $ax^2 + bx + c = 0$ $x = \frac{-b \pm \sqrt{b^2 - 4ac}}{2a}$

Lateral surface area, A , of cylinder of radius r , height h . $A = 2\pi rh$

Lateral surface area, A , of cone of radius r , sloping edge l . $A = \pi rl$

Surface area, A , of sphere of radius r . $A = 4\pi r^2$

Volume, V , of pyramid, base area A , height h . $V = \frac{1}{3}Ah$

Volume, V , of cone of radius r , height h . $V = \frac{1}{3}\pi r^2 h$

Volume, V , of sphere of radius r . $V = \frac{4}{3}\pi r^3$

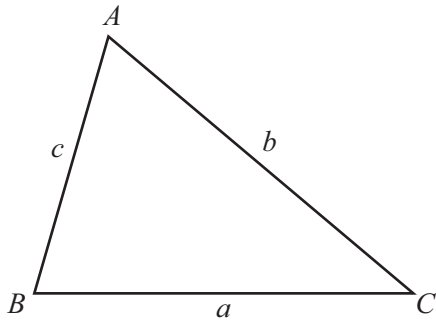

$$\frac{a}{\sin A} = \frac{b}{\sin B} = \frac{c}{\sin C}$$

$$a^2 = b^2 + c^2 - 2bc \cos A$$

$$\text{Area} = \frac{1}{2}bc \sin A$$

- 1 Ali leaves home at 1000 to cycle to his grandmother’s house. He arrives at 1300. The distance-time graph represents his journey.

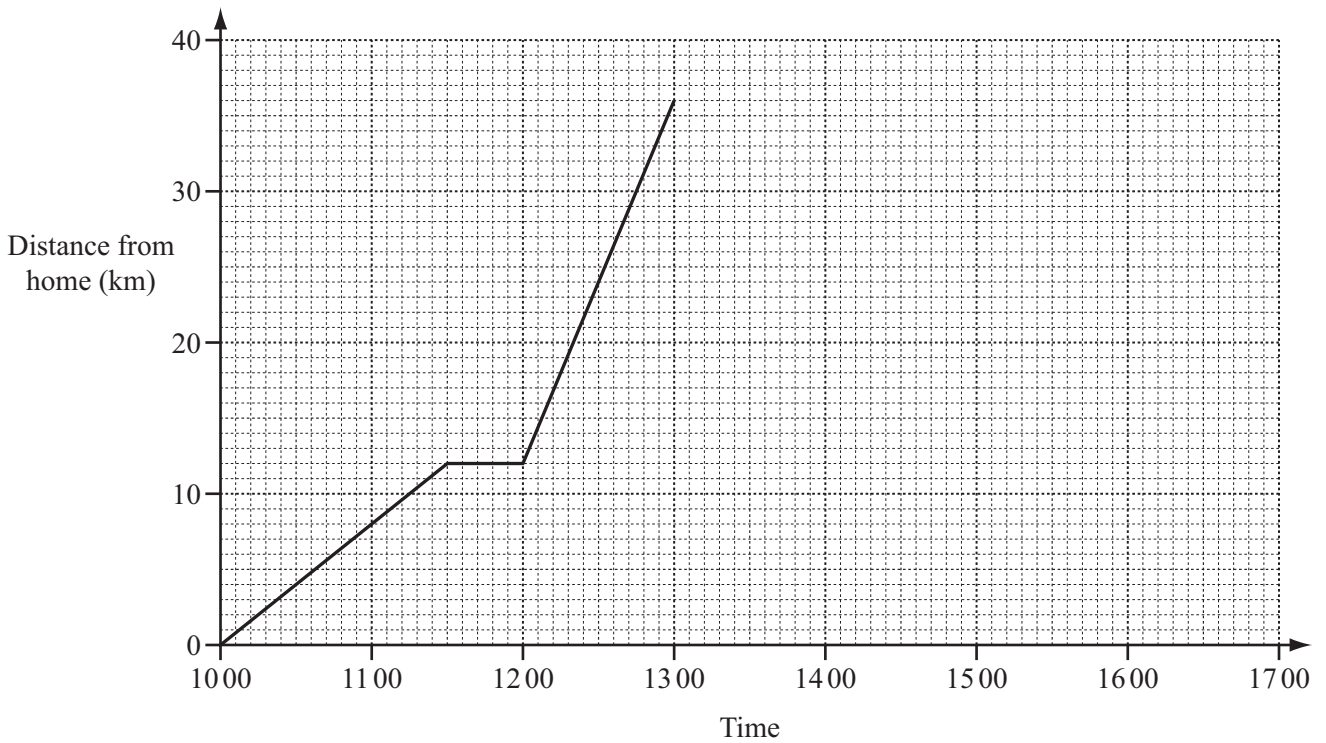

- (a) Calculate Ali’s speed between 1000 and 1130. Give your answer in kilometers per hour.

Answer(a) km/h [2]

- (b) Show that Ali’s average speed for the whole journey to his grandmother’s house is 12 km/h.

Answer(b)

[2]

- (c) Change 12 kilometers per hour into meters per minute.

Answer(c) m/min [2]

- (d) Ali stays for 45 minutes at his grandmother’s house and then returns home. He arrives home at 1642.

Complete the distance-time graph.

[2]

- 2 (a) The running costs for a papermill are \$75 246.
This amount is divided in the ratio labor costs : materials = 5 : 1.

Calculate the labor costs.

Answer(a) \$ [2]

- (b) In 2012 the company made a profit of \$135 890.
In 2013 the profit was \$150 675.

Calculate the percentage increase in the profit from 2012 to 2013.

Answer(b) % [3]

- (c) The profit of \$135 890 in 2012 was an increase of 7% on the profit in 2011.

Calculate the profit in 2011.

Answer(c) \$ [3]

- (d)

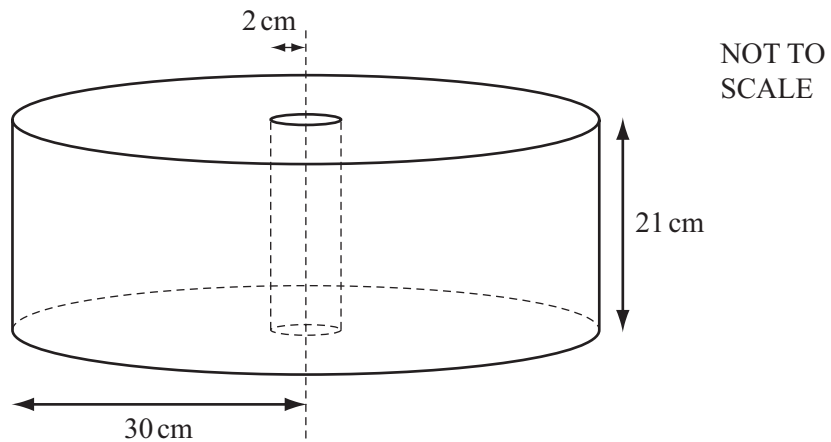

Paper is sold in cylindrical rolls.
There is a wooden cylinder of radius 2 cm and height 21 cm in the center of each roll.
The outer radius of a roll of paper is 30 cm.

- (i) Calculate the volume of paper in a roll.

Answer(d)(i) cm^3 [3]

- (ii) The paper is cut into sheets which measure 21 cm by 29.7 cm.
The thickness of each sheet is 0.125 mm.

(a) Change 0.125 millimeters into centimeters.

Answer(d)(ii)(a) cm [1]

(b) Work out how many whole sheets of paper can be cut from a roll.

Answer(d)(ii)(b) [4]

- (iii) 36 of the cylindrical rolls just fit into a container with their wooden cylinders vertical.
The container is a rectangular prism with base 2.4 meters by 1.8 meters.

Calculate the height of the rectangular prism.
Give your answer in meters.

Answer(d)(iii) m [3]

- 3 In the diagram, AE is parallel to BC and $CE = CD$.
 Angle $BCD = 90^\circ$, angle $BAE = 60^\circ$ and angle $AEC = 148^\circ$.

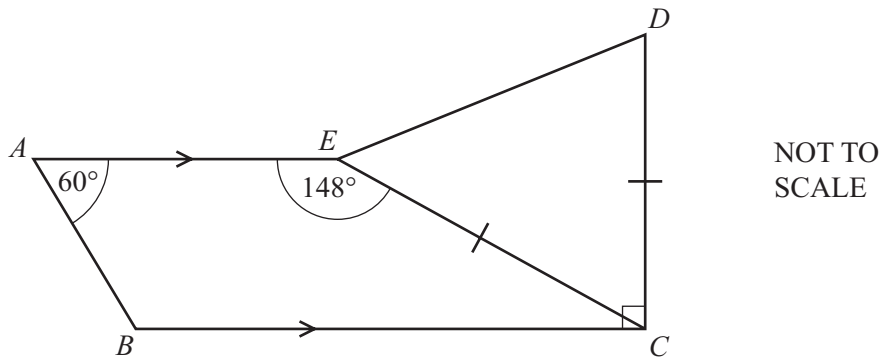

- (a) (i) Find angle ABC .

Answer(a)(i) Angle $ABC = \dots\dots\dots$ [1]

- (ii) Find the obtuse angle AED .

Answer(a)(ii) Angle $AED = \dots\dots\dots$ [4]

- (b)

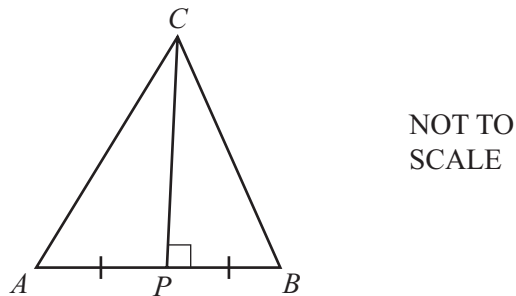

The diagram shows a triangle ABC .
 P is on AB so that CP is perpendicular to AB .
 $AP = PB$

Use congruent triangles to show that angle $CAB =$ angle CBA .

Answer(b)

[3]

(c)

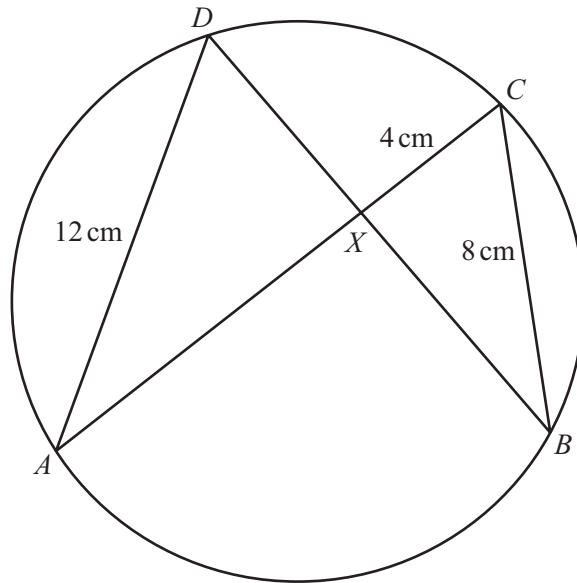
NOT TO
SCALE

A , B , C and D lie on the circle.
The chords AC and BD intersect at X .

- (i) Explain why triangles ADX and BCX are similar.

Answer(c)(i)

[3]

- (ii) $AD = 12$ cm, $CX = 4$ cm and $CB = 8$ cm.

Calculate the length of DX .

Answer(c)(ii) $DX = \dots\dots\dots$ cm [2]

- (iii) The area of triangle $ADX = 18k$ square centimeters.

Find, in terms of k , the area of triangle BCX .

Answer(c)(iii) $\dots\dots\dots$ cm² [2]

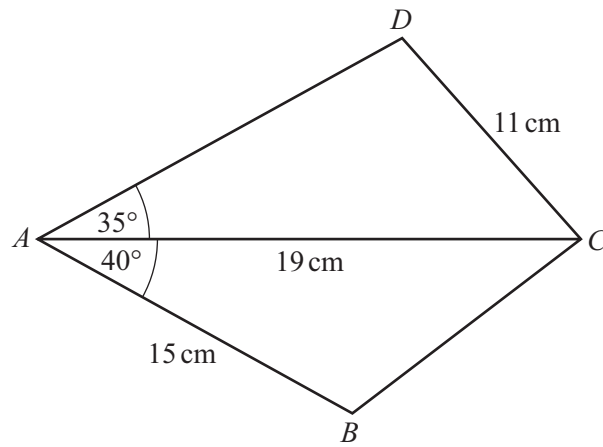

NOT TO
SCALE

- (a) Calculate the area of triangle BAC .

Answer(a) cm^2 [2]

- (b) Calculate the length BC .

Answer(b) $BC =$ cm [3]

(c) Angle ADC is obtuse.

Calculate angle ADC .

Answer(c) Angle ADC = [4]

- 5 (a) A square spinner is biased.
The probabilities of obtaining the scores 1, 2, 3 and 4 when it is spun are given in the table.

Score	1	2	3	4
Probability	0.1	0.2	0.4	0.3

- (i) Work out the probability that on one spin the score is 2 or 3.

Answer(a)(i) [2]

- (ii) In 5000 spins, how many times would you expect to score 4 with this spinner?

Answer(a)(ii) [1]

- (iii) Work out the probability of scoring 1 on the first spin and 4 on the second spin.

Answer(a)(iii) [2]

- (b) In a bag there are 7 red discs and 5 blue discs.
From the bag a disc is chosen at random and not replaced.
A second disc is then chosen at random.

Work out the probability that at least one of the discs is red.
Give your answer as a fraction.

Answer(b) [3]

6

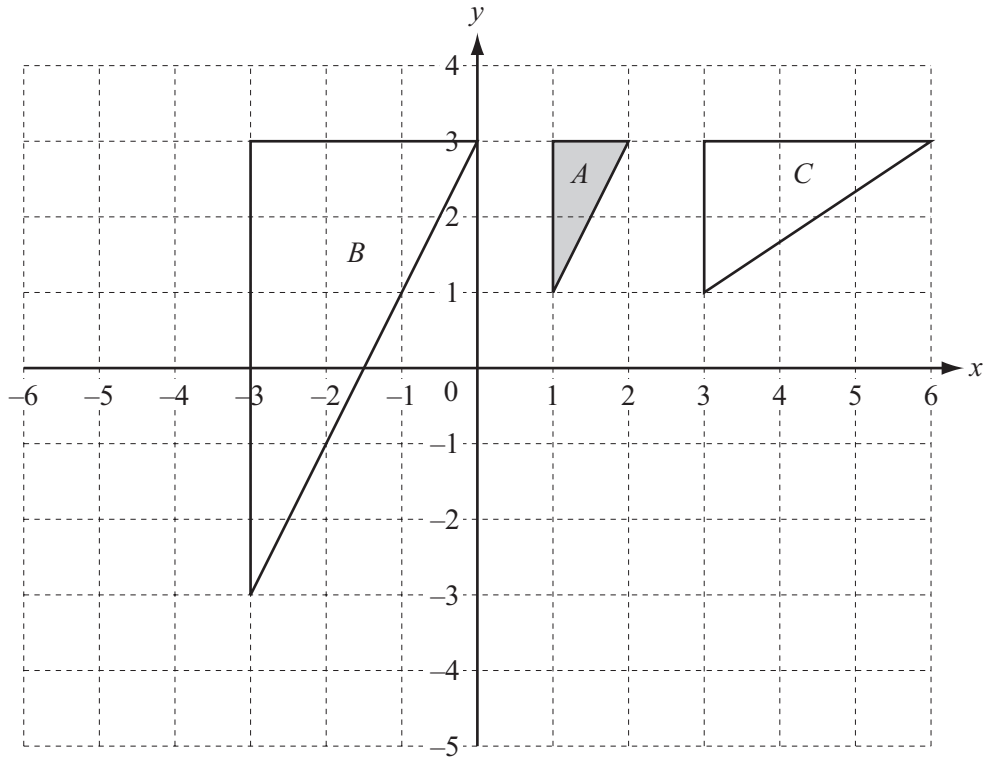

(a) On the grid,

(i) draw the image of shape *A* after a translation by the vector $\begin{pmatrix} -6 \\ -4 \end{pmatrix}$, [2]

(ii) draw the image of shape *A* after a rotation through 90° clockwise about the origin. [2]

(b) Describe fully the single transformation that maps

(i) triangle *A* onto triangle *B*,

Answer(b)(i)

..... [3]

(ii) triangle *A* onto triangle *C*.

Answer(b)(ii)

..... [3]

7 (a) Complete the table of values for $y = x^3 - 3x + 1$.

x	-2.5	-2	-1.5	-1	-0.5	0	0.5	1	1.5	2	2.5
y	-7.125	-1		3		1	-0.375	-1	-0.125	3	9.125

[2]

(b) Draw the graph of $y = x^3 - 3x + 1$ for $-2.5 \leq x \leq 2.5$.

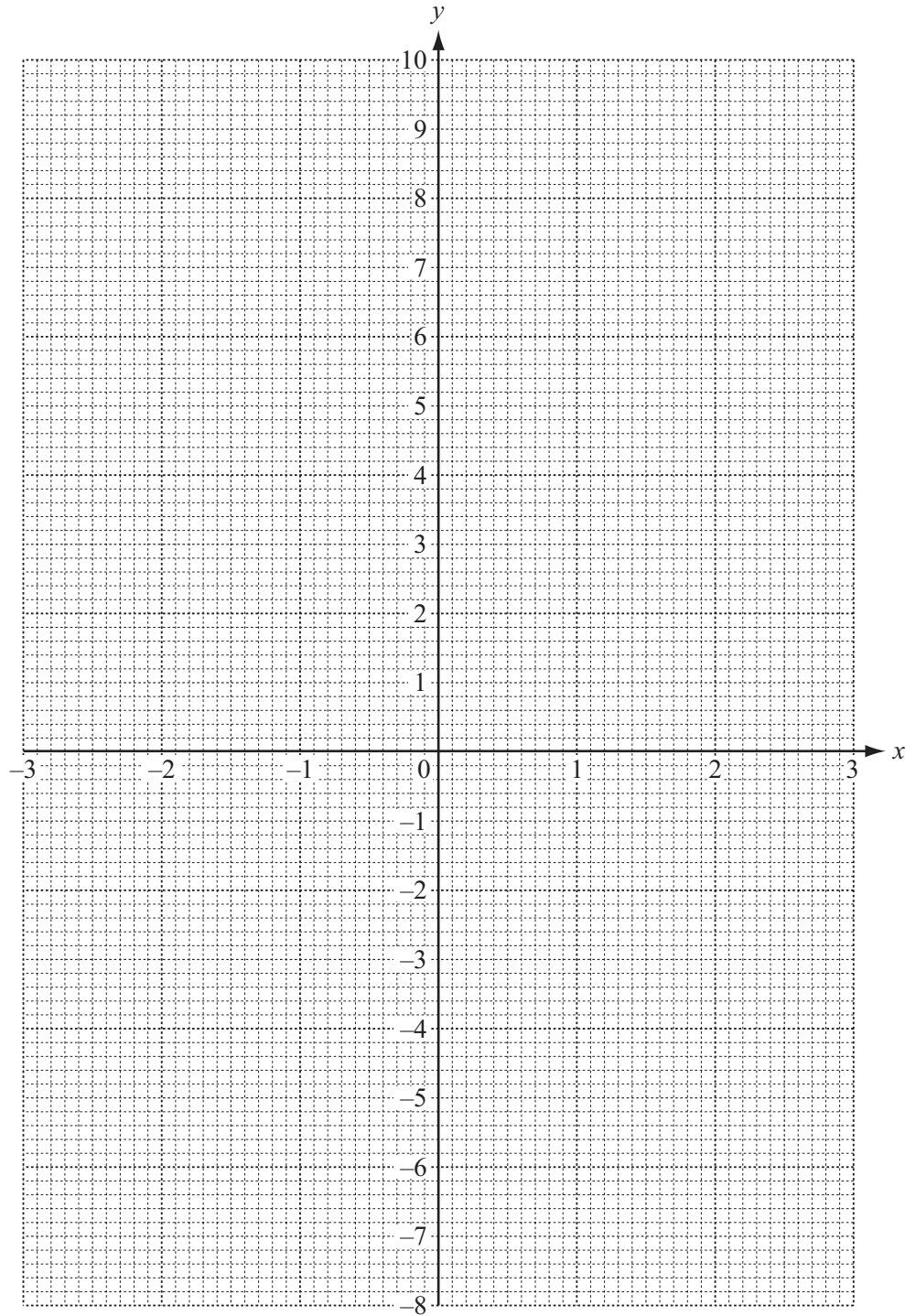

[4]

(c) By drawing a suitable tangent, estimate the slope of the curve at the point where $x = 2$.

Answer(c) [3]

(d) Use your graph to solve the equation $x^3 - 3x + 1 = 1$.

Answer(d) $x =$ or $x =$ or $x =$ [2]

(e) Use your graph to complete the inequality in k for which the equation

$x^3 - 3x + 1 = k$ has three different solutions.

Answer(e) $< k <$ [2]

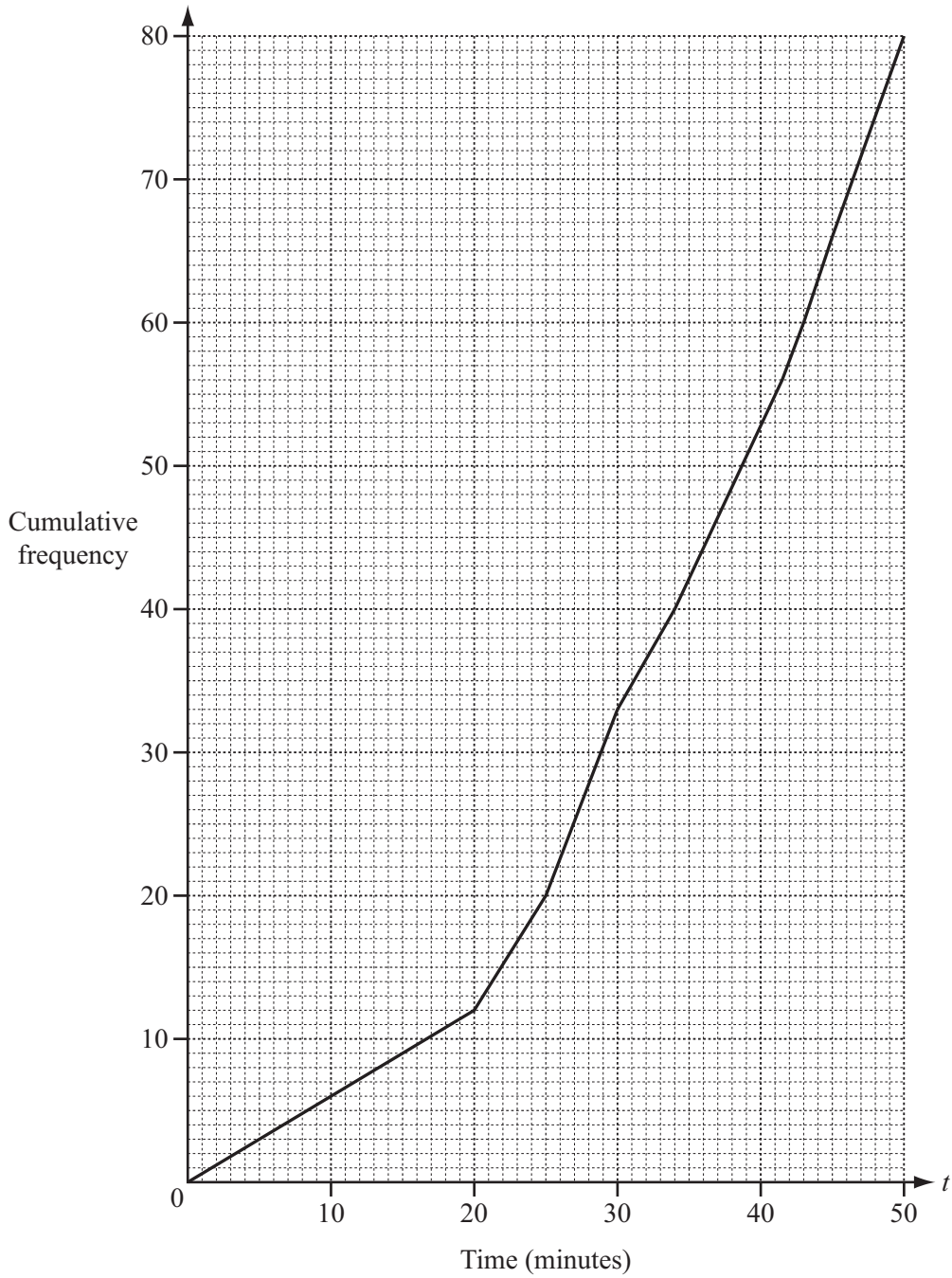

The times (t minutes) taken by 80 people to complete a charity swim were recorded. The results are shown in the cumulative frequency diagram above.

(a) Find

(i) the median,

Answer(a)(i) min [1]

(ii) the inter-quartile range,

Answer(a)(ii) min [2]

(iii) the 70th percentile.

Answer(a)(iii) min [2]

(b) The times taken by the 80 people are shown in this grouped frequency table.

Time (t minutes)	$0 < t \leq 20$	$20 < t \leq 30$	$30 < t \leq 45$	$45 < t \leq 50$
Frequency	12	21	33	14

(i) Calculate an estimate of the mean time.

Answer(b)(i) min [4]

(ii) Draw a histogram to represent the grouped frequency table.

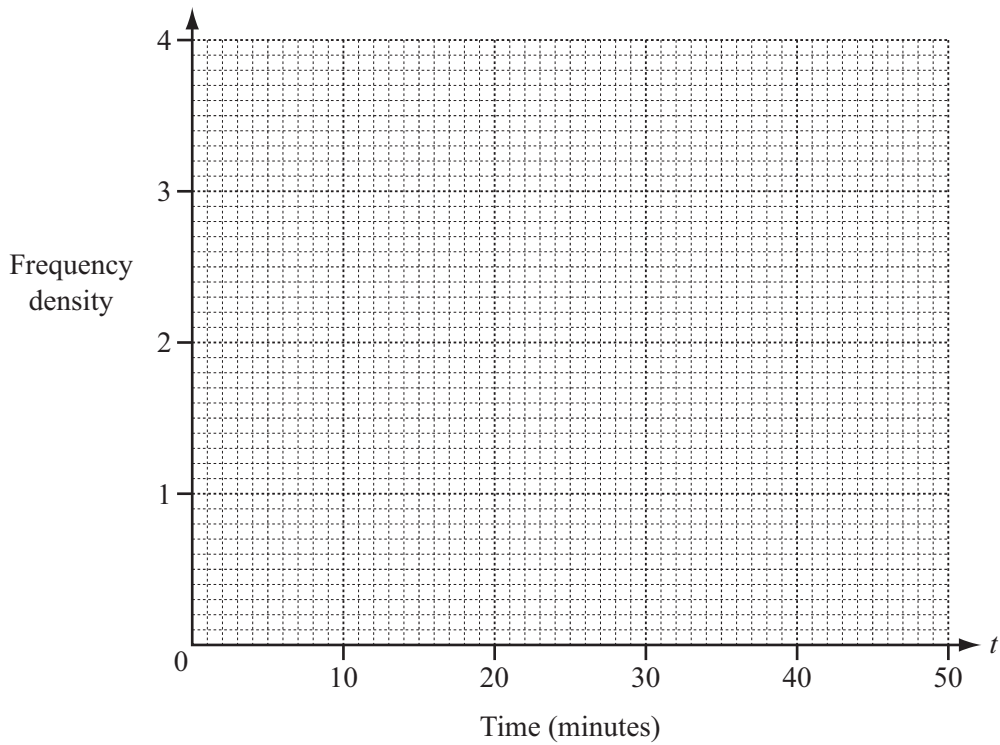

[4]

9 (a) $f(x) = 2x - 3$ $g(x) = \frac{1}{x+1} + 2$ $h(x) = 3^x$

(i) Find $f(4)$.

Answer(a)(i) [1]

(ii) Find $f(h(-1))$.

Answer(a)(ii) [2]

(iii) Find $f^{-1}(x)$, the inverse of $f(x)$.

Answer(a)(iii) $f^{-1}(x) =$ [2]

(iv) Find $f(f(x))$ in its simplest form.

Answer(a)(iv) $f(f(x)) =$ [2]

- (v) Show that the equation $f(x) = g(x)$ simplifies to $2x^2 - 3x - 6 = 0$.

Answer(a)(v)

[3]

- (vi) Solve the equation $2x^2 - 3x - 6 = 0$.

Give your answers correct to 2 decimal places.
Show all your working.

Answer(a)(vi) $x = \dots\dots\dots$ or $x = \dots\dots\dots$ [4]

- (b) Simplify $\frac{x^2 - 3x + 2}{x^2 + 3x - 10}$.

Answer(b) $\dots\dots\dots$ [4]

10 (a) $\vec{PQ} = \begin{pmatrix} -3 \\ 4 \end{pmatrix}$

(i) P is the point $(-2, 3)$.

Work out the co-ordinates of Q .

Answer(a)(i) (.....,) [1]

(ii) Work out $|\vec{PQ}|$, the magnitude of \vec{PQ} .

Answer(a)(ii) [2]

(b)

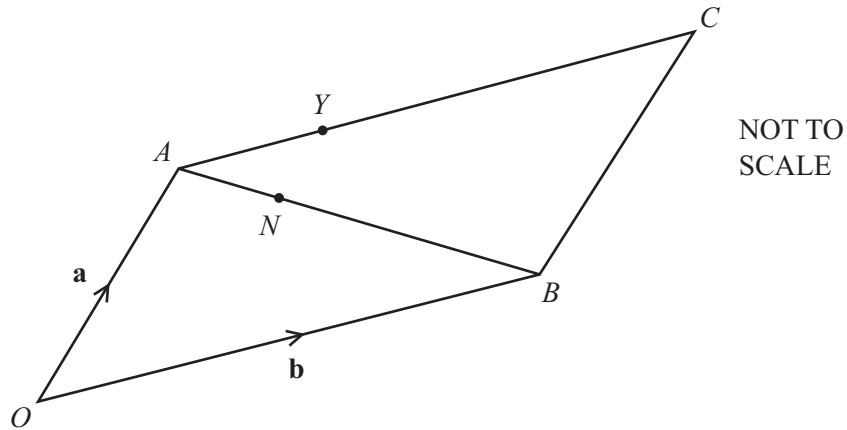

$OACB$ is a parallelogram.

$\vec{OA} = \mathbf{a}$ and $\vec{OB} = \mathbf{b}$.

$AN:NB = 2:3$ and $AY = \frac{2}{5}AC$.

(i) Write each of the following in terms of \mathbf{a} and/or \mathbf{b} .
Give your answers in simplest form.

(a) \vec{ON}

Answer(b)(i)(a) $\vec{ON} = \dots\dots\dots$ [2]

(b) \vec{NY}

Answer(b)(i)(b) $\vec{NY} = \dots\dots\dots$ [2]

(ii) Write down two conclusions you can make about the line segments NY and BC .

Answer(b)(ii) $\dots\dots\dots$
 $\dots\dots\dots$ [2]

Question 11 is printed on the next page.

11 (a) $f(x) = x^2 - 3x + 1$

(i) Write $f(x)$ in the form $(x - a)^2 + b$.

Answer(a)(i) [2]

(ii) Find the coordinates of the minimum point of the graph of $y = f(x)$.

Answer(a)(ii) (.....,) [2]

(b)

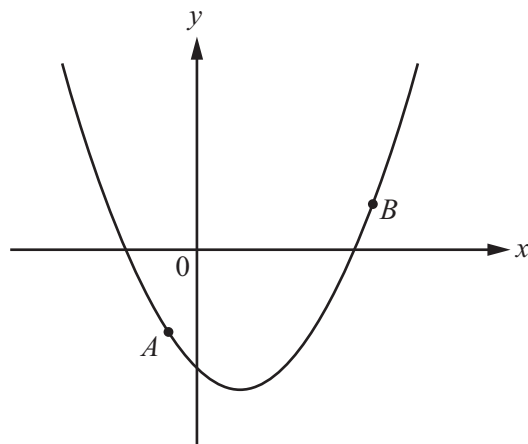

NOT TO SCALE

The diagram shows a sketch of the graph of $y = x^2 + px + q$.
The points $A(-1, -3)$ and $B(4, 2)$ are both on the graph.

Find the values of p and q .

Answer(b) $p =$

$q =$ [4]

Permission to reproduce items where third-party owned material protected by copyright is included has been sought and cleared where possible. Every reasonable effort has been made by the publisher (UCLES) to trace copyright holders, but if any items requiring clearance have unwittingly been included the publisher will be pleased to make amends at the earliest possible opportunity.

Cambridge International Examinations is part of the Cambridge Assessment Group. Cambridge Assessment is the brand name of University of Cambridge Local Examinations Syndicate (UCLES), which is itself a department of the University of Cambridge.