



# Cambridge IGCSE™

CANDIDATE  
NAME

--

CENTRE  
NUMBER

--	--	--	--	--

CANDIDATE  
NUMBER

--	--	--	--

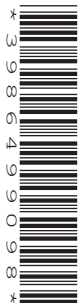

**MATHEMATICS**

**0580/43**

Paper 4 (Extended)

**October/November 2020**

**2 hours 30 minutes**

You must answer on the question paper.

You will need: Geometrical instruments

## INSTRUCTIONS

- Answer **all** questions.
- Use a black or dark blue pen. You may use an HB pencil for any diagrams or graphs.
- Write your name, centre number and candidate number in the boxes at the top of the page.
- Write your answer to each question in the space provided.
- Do **not** use an erasable pen or correction fluid.
- Do **not** write on any bar codes.
- You should use a calculator where appropriate.
- You may use tracing paper.
- You must show all necessary working clearly.
- Give non-exact numerical answers correct to 3 significant figures, or 1 decimal place for angles in degrees, unless a different level of accuracy is specified in the question.
- For  $\pi$ , use either your calculator value or 3.142.

## INFORMATION

- The total mark for this paper is 130.
- The number of marks for each question or part question is shown in brackets [ ].

This document has **20** pages. Blank pages are indicated.

1 (a) The Earth has a surface area of approximately  $510\,100\,000\text{ km}^2$ .

(i) Write this surface area in standard form.

.....  $\text{km}^2$  [1]

(ii) Water covers 70.8% of the Earth's surface.

Work out the area of the Earth's surface covered by water.

.....  $\text{km}^2$  [2]

(b) The table shows the surface area of some countries and their estimated population in 2017.

Country	Surface area ( $\text{km}^2$ )	Estimated population in 2017
Brunei	$5.77 \times 10^3$	433 100
China	$9.60 \times 10^6$	1 388 000 000
France	$6.41 \times 10^5$	67 000 000
Maldives	$3.00 \times 10^2$	374 600

(i) Find the total surface area of Brunei and the Maldives.

.....  $\text{km}^2$  [1]

(ii) The ratio surface area of the Maldives : surface area of China can be written in the form  $1 : n$ .

Find the value of  $n$ .

$n =$  ..... [2]

(iii) Find the surface area of France as a percentage of the surface area of China.

..... % [2]

- (iv) Find the population density of the Maldives.  
[Population density = population  $\div$  surface area]

.....people/km<sup>2</sup> [2]

- (c) The population of the Earth in 2017 was estimated to be  $7.53 \times 10^9$ .

The population of the Earth in 2000 was estimated to be  $6.02 \times 10^9$ .

- (i) Work out the percentage increase in the Earth's estimated population from 2000 to 2017.

..... % [2]

- (ii) Assume that the population of the Earth increased exponentially by  $y\%$  each year for these 17 years.

Find the value of  $y$ .

$y =$  ..... [3]

2

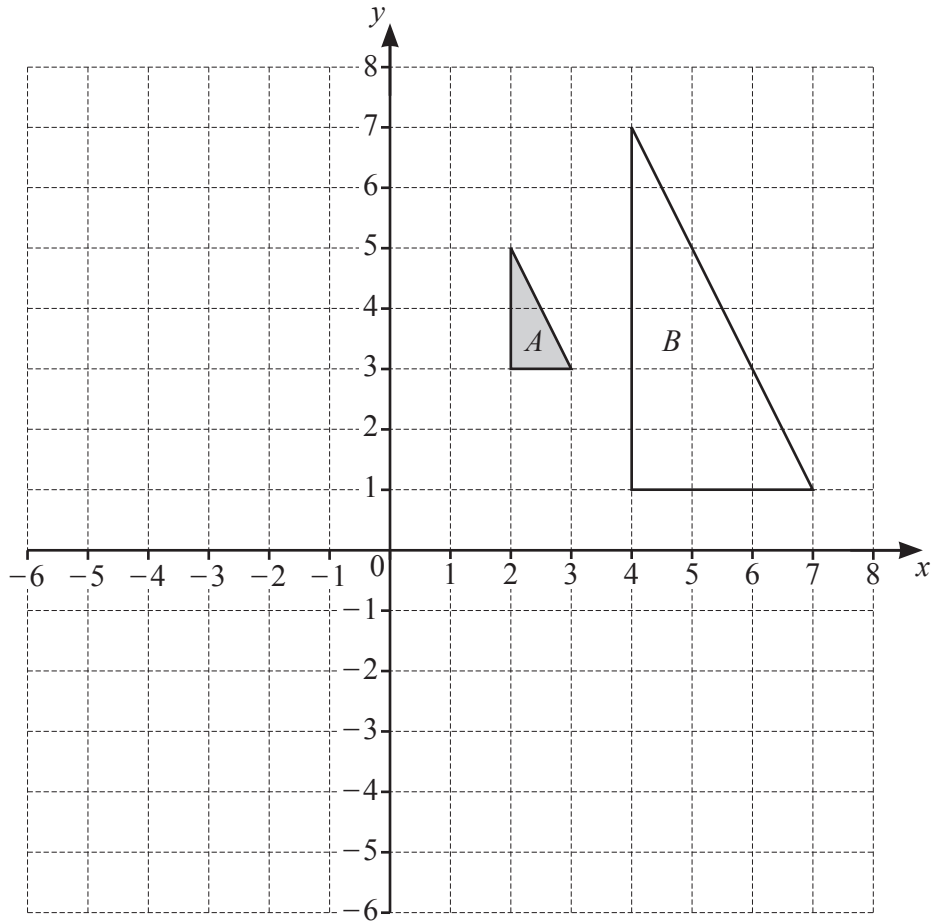

(a) On the grid, draw the image of

(i) triangle  $A$  after a rotation of  $90^\circ$  anticlockwise about  $(0, 0)$ , [2]

(ii) triangle  $A$  after a translation by the vector  $\begin{pmatrix} 3 \\ -5 \end{pmatrix}$ . [2]

(b) Describe fully the **single** transformation that maps triangle  $A$  onto triangle  $B$ .

.....

..... [3]

- 3 (a) The average speeds, in km/h, of cars travelling along a road are recorded. The box-and-whisker plot shows this information.

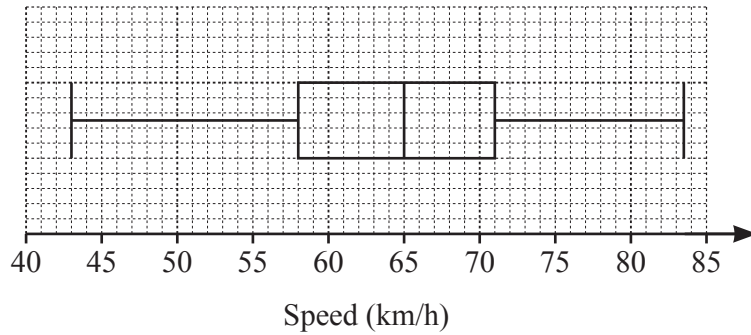

Find

- (i) the lowest speed recorded,

..... km/h [1]

- (ii) the median,

..... km/h [1]

- (iii) the interquartile range.

..... km/h [1]

- (b) Another car takes 18 seconds to travel 400 m along this road.

Calculate the average speed of this car in km/h.

..... km/h [3]

4

P	O	S	S	I	B	I	L	I	T	Y
---	---	---	---	---	---	---	---	---	---	---

Morgan picks two of these letters, at random, **without** replacement.

(a) Find the probability that he picks

(i) the letter Y first,

..... [1]

(ii) the letter B then the letter Y,

..... [2]

(iii) two letters that are the same.

..... [3]

(b) Morgan now picks a third letter at random.

Find the probability that

(i) all three letters are the same,

..... [2]

(ii) exactly two of the three letters are the same,

..... [5]

(iii) all three letters are different.

..... [2]

5 (a)

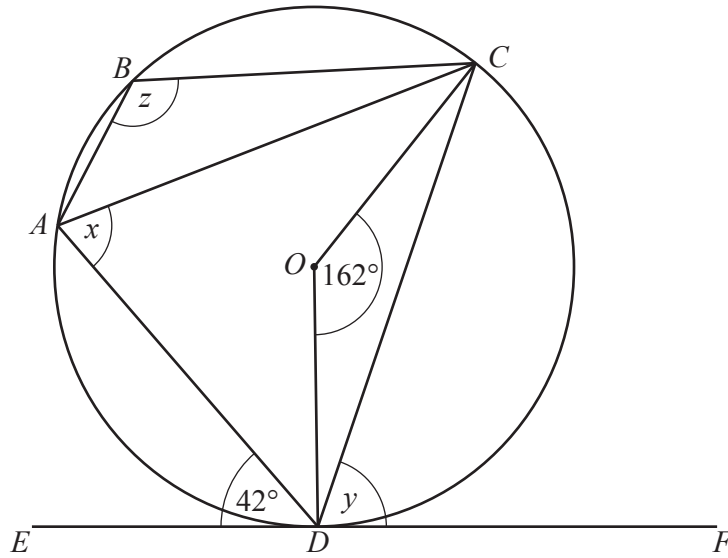

NOT TO SCALE

$A, B, C$  and  $D$  are points on the circle, centre  $O$ .  
 $EF$  is a tangent to the circle at  $D$ .  
 Angle  $ADE = 42^\circ$  and angle  $COD = 162^\circ$ .

Find the following angles, giving reasons for each of your answers.

(i) Angle  $x$

$x = \dots\dots\dots$  because  $\dots\dots\dots$   
 $\dots\dots\dots$  [2]

(ii) Angle  $y$

$y = \dots\dots\dots$  because  $\dots\dots\dots$   
 $\dots\dots\dots$  [2]

(iii) Angle  $z$

$z = \dots\dots\dots$  because  $\dots\dots\dots$   
 $\dots\dots\dots$   
 $\dots\dots\dots$  [3]



(b)

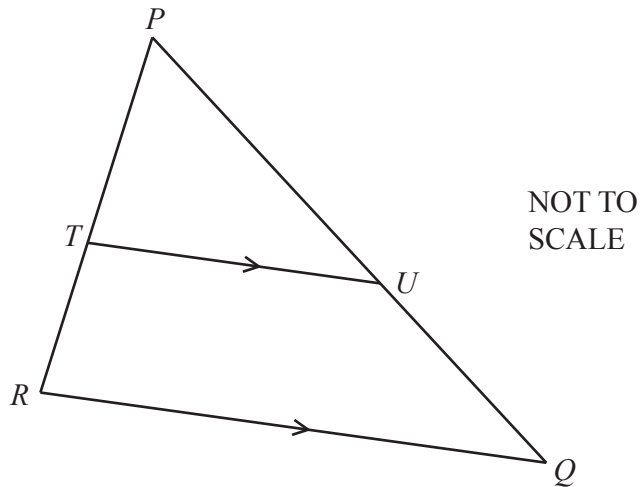

$PQR$  is a triangle.  
 $T$  is a point on  $PR$  and  $U$  is a point on  $PQ$ .  
 $RQ$  is parallel to  $TU$ .

- (i) Explain why triangle  $PQR$  is similar to triangle  $PUT$ .  
 Give a reason for each statement you make.

.....  
 .....  
 .....  
 ..... [3]

- (ii)  $PT : TR = 4 : 3$

- (a) Find the ratio  $PU : PQ$ .

..... : ..... [1]

- (b) The area of triangle  $PUT$  is  $20 \text{ cm}^2$ .

Find the area of the quadrilateral  $QRTU$ .

.....  $\text{cm}^2$  [3]

6

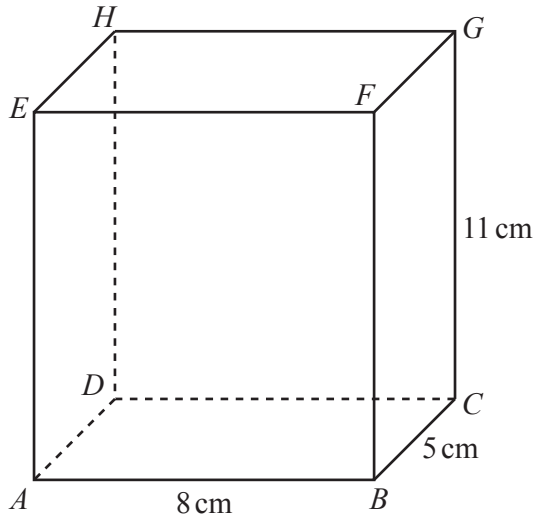

NOT TO SCALE

*ABCDEFGH* is a cuboid.  
 $AB = 8\text{ cm}$ ,  $BC = 5\text{ cm}$  and  $CG = 11\text{ cm}$ .

(a) Work out the volume of the cuboid.

.....  $\text{cm}^3$  [2]

(b) Ivana has a pencil of length 13 cm.

Does this pencil fit completely inside the cuboid?  
Show how you decide.

[4]

(c) (i) Calculate angle  $CAB$ .

Angle  $CAB = \dots\dots\dots$  [2]

(ii) Calculate angle  $GAC$ .

Angle  $GAC = \dots\dots\dots$  [2]

7 (a) (i) Factorise  $24 + 5x - x^2$ .

..... [2]

(ii) The diagram shows a sketch of  $y = 24 + 5x - x^2$ .

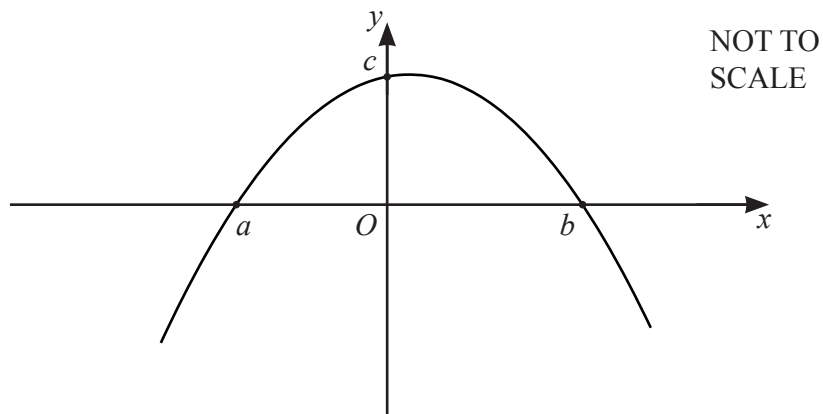

Work out the values of  $a$ ,  $b$  and  $c$ .

$a =$  .....

$b =$  .....

$c =$  ..... [3]

(iii) Calculate the gradient of  $y = 24 + 5x - x^2$  at  $x = -1.5$ .

..... [3]

- (b) (i) On the diagram, sketch the graph of  $y = (x+1)(x-3)^2$ .  
Label the values where the graph meets the  $x$ -axis and the  $y$ -axis.

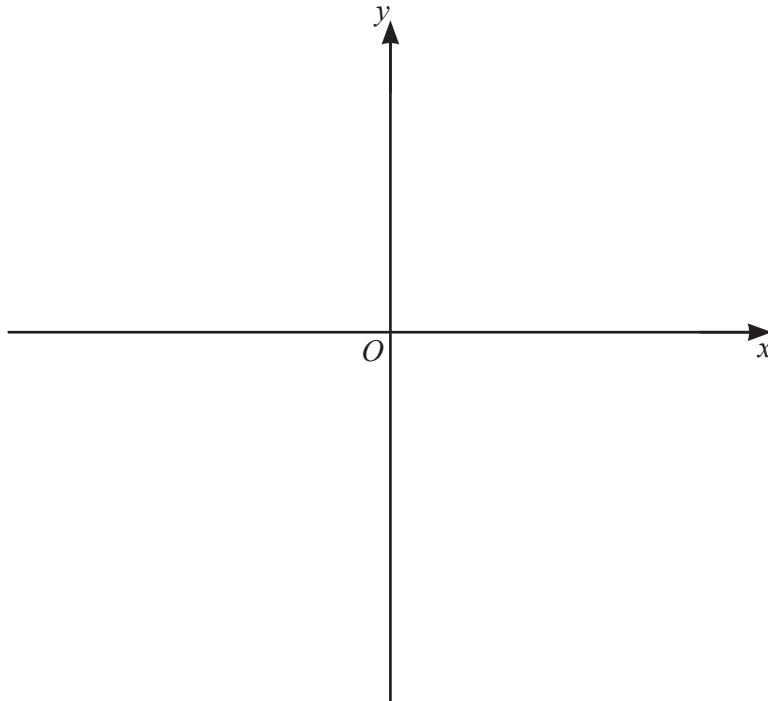

[4]

- (ii) Write  $(x+1)(x-3)^2$  in the form  $ax^3 + bx^2 + cx + d$ .

..... [3]

$$8 \quad (a) \quad \vec{AB} = \begin{pmatrix} 6 \\ -1 \end{pmatrix} \quad \vec{BC} = \begin{pmatrix} -2 \\ 5 \end{pmatrix} \quad \vec{DC} = \begin{pmatrix} 2 \\ -3 \end{pmatrix}$$

Find

(i)  $\vec{AC}$ ,

$$\vec{AC} = \begin{pmatrix} \quad \\ \quad \end{pmatrix} [2]$$

(ii)  $\vec{BD}$ ,

$$\vec{BD} = \begin{pmatrix} \quad \\ \quad \end{pmatrix} [2]$$

(iii)  $|\vec{BC}|$ .

..... [2]

(b)

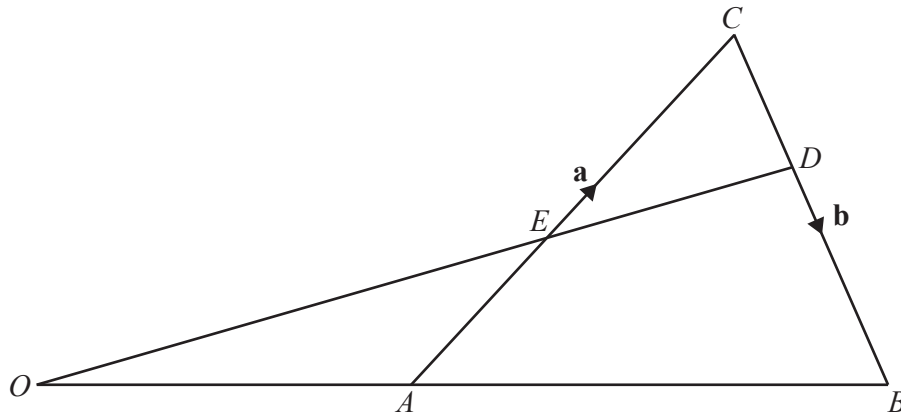

NOT TO SCALE

In the diagram,  $OAB$  and  $OED$  are straight lines.  
 $O$  is the origin,  $A$  is the midpoint of  $OB$  and  $E$  is the midpoint of  $OC$ .  
 $\vec{AC} = \mathbf{a}$  and  $\vec{CB} = \mathbf{b}$ .

Find, in terms of  $\mathbf{a}$  and  $\mathbf{b}$ , in its simplest form

(i)  $\vec{AB}$ ,

$\vec{AB} = \dots\dots\dots$  [1]

(ii)  $\vec{OE}$ ,

$\vec{OE} = \dots\dots\dots$  [2]

(iii) the position vector of  $D$ .

$\dots\dots\dots$  [3]

- 9 (a) Find the integer values that satisfy the inequality  $2 < 2x \leq 10$ .

..... [2]

- (b) Factorise completely.

(i)  $6y^2 - 15xy$

..... [2]

(ii)  $y^2 - 9x^2$

..... [2]

- (c) Simplify.

$$\frac{3}{x-1} - \frac{2}{2x+1}$$

..... [3]



- (d) The straight line  $y = 3x + 2$  intersects the curve  $y = 2x^2 + 7x - 11$  at two points.

Find the coordinates of these two points.

Give your answers correct to 2 decimal places.

(....., .....) )

(....., .....) [6]

10  $f(x) = 4 - 3x$        $g(x) = x^2 + x$        $h(x) = 3^x$

(a) Find  $fh(2)$ .

..... [2]

(b) Find  $f^{-1}(x)$ .

$f^{-1}(x) =$  ..... [2]

(c) Simplify.

(i)  $f(1 - 2x)$

..... [2]

(ii)  $gf(x) - 9g(x)$

..... [4]

(d)  $\frac{1}{h(x)} = 9^{kx}$

Find the value of  $k$ .

$k =$  ..... [2]

- 11 The table shows the first four terms in sequences  $A$ ,  $B$ , and  $C$ .

Sequence	1st term	2nd term	3rd term	4th term	5th term		$n$ th term
$A$	4	9	14	19			
$B$	3	10	29	66			
$C$	1	4	16	64			

Complete the table.

[9]

**BLANK PAGE**

---

Permission to reproduce items where third-party owned material protected by copyright is included has been sought and cleared where possible. Every reasonable effort has been made by the publisher (UCLES) to trace copyright holders, but if any items requiring clearance have unwittingly been included, the publisher will be pleased to make amends at the earliest possible opportunity.

To avoid the issue of disclosure of answer-related information to candidates, all copyright acknowledgements are reproduced online in the Cambridge Assessment International Education Copyright Acknowledgements Booklet. This is produced for each series of examinations and is freely available to download at [www.cambridgeinternational.org](http://www.cambridgeinternational.org) after the live examination series.

Cambridge Assessment International Education is part of the Cambridge Assessment Group. Cambridge Assessment is the brand name of the University of Cambridge Local Examinations Syndicate (UCLES), which itself is a department of the University of Cambridge.